



DA-20
Display Aerator
1/3 HP - 1 HP

North Star
Aerating Fountain
1/3 HP - 1 HP

We at Scott Aerator thank you for your purchase. It is our goal to ensure that you are completely satisfied with your new Display Aerator and that it continues to operate smoothly for many years to come. Please take a few moments to read through this document for proper assembly, installation and maintenance to maximize the operating life of the unit.



This Kit Includes

- 1 - FLOAT PLATFORM
- 1 - PUMP ASSEMBLY
- 1 - STAINLESS DEBRIS SHIELD
- 3 - SELF TAPPING SCREWS

Tools Needed

- ONE 3/8" WRENCH OR SOCKET SCREWDRIVER
- TWO 1/2" WRENCHES (OR PLIERS)



Assembly Instructions

1. Remove the two stainless steel bolts from the float. Fig. 1
2. Place pump assembly on end, propeller side facing up. Slip the float platform, with the Scott Aerator name and phone number facing up, over the pump assembly, aligning the two holes on the float platform to the pre-drilled holes on the pump assembly. Use the pre-drilled holes to fasten the float platform to the pump assembly, using the two stainless-steel bolts.
3. Turn the pump and float assembly over and place on its opposite end. Remove and discard the protective packaging and secure the stainless-steel filter basket by aligning the three filter holes to the pre-drilled holes on the pump assembly and securing with the enclosed self-tapping screws. Fig. 3
4. Secure a 3/8" or thicker nylon anchoring line (not provided) to each of the two attached eye bolts. Fig. 2 Make sure lines are long enough to extend outwards, 25 feet apart at a 45° angle to the pond or lake bottom. (Fig. 7 back page)
5. At this point, your Display Aerator can be floated into position in your pond or lake. Once a suitable location is determined, simply attach a boat anchor, concrete block, or similar weighted item to each of the two nylon lines (refer to Fig. 5 for minimum anchor weight for your size aerator). Once attached, place the anchors at the bottom of the pond spaced a minimum of twenty-five feet apart.
6. The final step is to supply electric power to your Display Aerator, taking extra caution to **always use a ground fault circuit interrupter and a licensed electrical contractor**. See Fig. 6 for guidelines on supplying power.

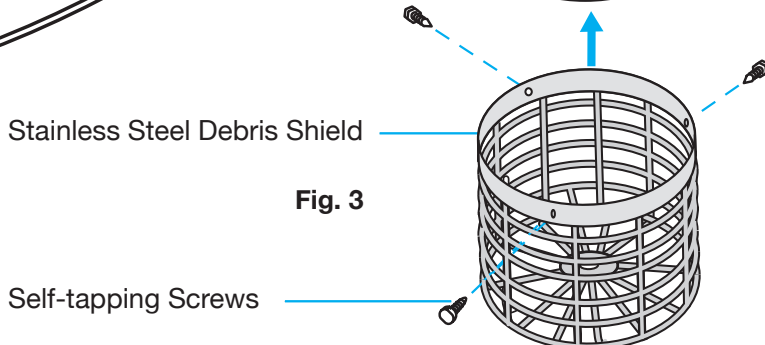
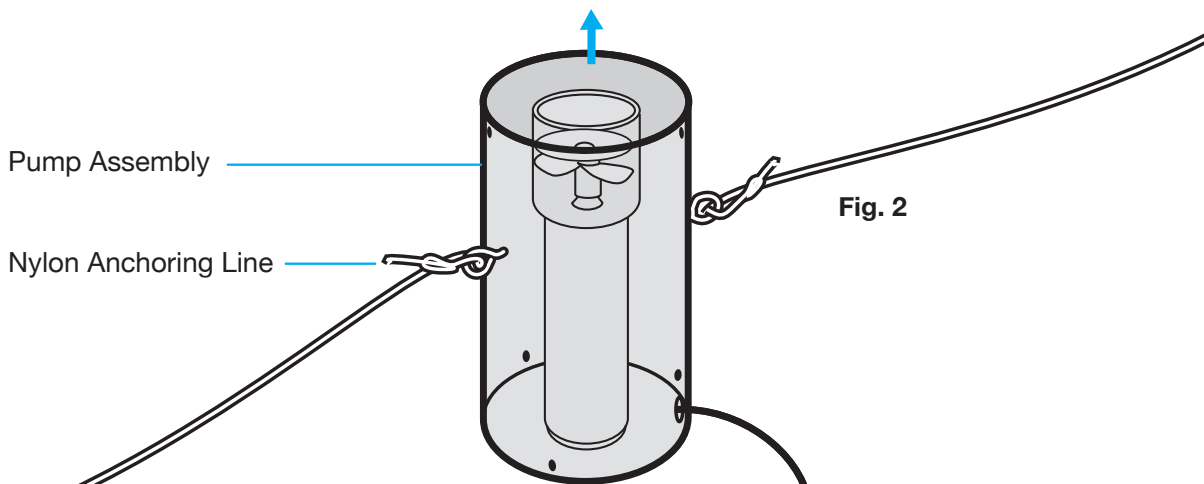
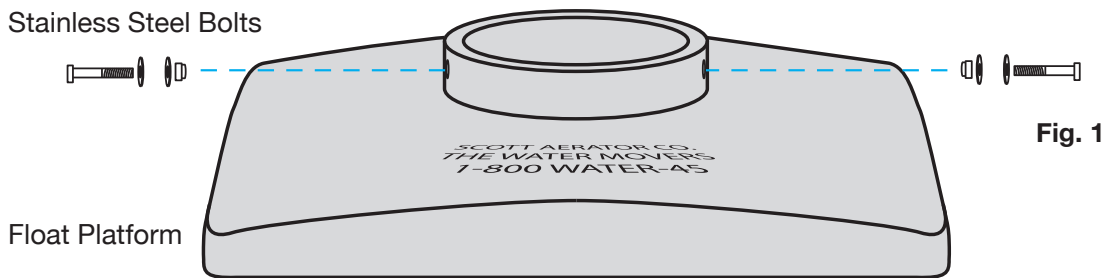

! Always use a GFCI
! Always disconnect the power
when swimmers are present

! Do NOT use an extension cord
to supply power to the motor

Maintaining your DA-20 Display Aerator

Most of our products require very little to any maintenance. Under normal operating conditions, you should enjoy many years of trouble free service from the unit. As a rule of thumb, the propeller assembly on our aerator fountains should be changed every five years. This is a simple procedure that can be done on-site. Refer to Fig. 4 for replacement parts. Anchoring ropes, depending on type, will deteriorate over time. These too should be replaced every five years if quality nylon rope (3/8" or thicker) is utilized. When the unit is removed from the water for the propeller and rope switch, it would be a good opportunity to wash the unit down with high pressure water. Once the unit is clean, a visual inspection of the entire aerator is recommended to be certain nothing is restricting water flow.

The Scott Aerator Company has engineered all of its water features to eliminate the need for time consuming and costly winterizing products and procedures. **Removing the Aerator from the water each winter will dry out and potentially damage the pump seals.** Simply leave your aerator in the water, turn the power supply off, and forget about it for the winter. Once the water thaws in the spring, re-establish power to the unit and you're good to go. All of the components will withstand sub-zero conditions without damage.

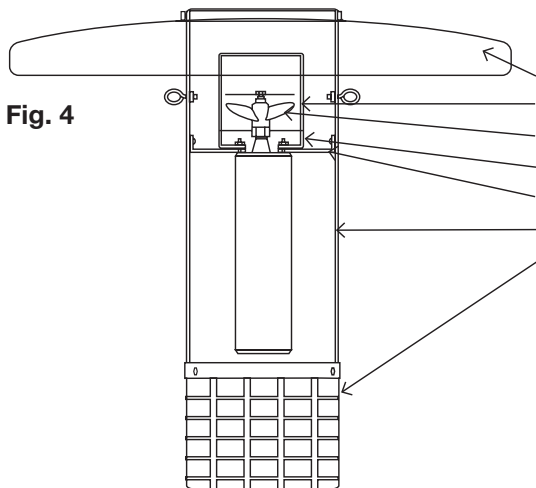

Fig. 4

Call 1-800-928-3745 to order replacement parts

- FLOAT PLATFORM PART # 20037
- PROPELLER HOUSING PART # 30010
- PROPELLER..... PART # 30006
- SS L-BRACKET PART # 20201
- SS MOTOR MOUNTING BRACKET... PART # 20115
- DA-20 MOTOR HOUSING..... PART # 20034
- WIRE BASKET PART # 20045
- 70 FT POWER CORD PART # 27010
- 100 FT POWER CORD PART # 27100
- 1/3 HP 115V MOTOR PART # 20008
- 1/2 HP 115V MOTOR PART # 20000
- 1/2 HP 230V MOTOR PART # 20002
- 3/4 HP 230V MOTOR PART # 20003
- 1 HP 230V MOTOR PART # 20004

Fig. 5

	MOTOR RATING						
	1/3 HP 115V	1/2 HP 115V/230V	3/4 HP 230V	1 HP 230V	1-1/2 HP 230V	2 HP 230V	3 HP 230V
WATTS	630	670	680	1217	1770	2025	3000
AMPS	8	10/5	7	8.2	10.6	12	13.5
SPRAY HEIGHT	5'	6.5'	6.8'	7'	10'	11'	11'
SPRAY DIA (FT)	18'	22'	23'	25'	25'	28'	30'
GALLONS/MIN	300	400	450	500	600	700	800
MIN ANCHOR WT (ea)	20 lbs	25 lbs	20 lbs	35 lbs	45 lbs	45 lbs	55 lbs
POWER CORD* 12 GAUGE	70'	70'	70'	70'	100'	100'	100'

*Longer power cords available ** 5HP motor incorporates 10 gauge power cord

To find the cost to run one item:

1. Total up the watts per day for the item to get total watts/day.
2. Divide total watts/day by 1000 to get the total kilowatt hours (kWh) per day.
3. Multiply the kWh/day times the cost per Kwh to get cost/day.
4. To find out the average cost per month, multiply the cost/day by 30. (Power company monthly billing cycles vary from 28-33 days)

Fig. 6

MOTOR RATING	CABLE SIZE and MAX LENGTH FROM PUMP TO BREAKER*					
	12AWG	10AWG	8AWG	6AWG	4AWG	2AWG
1/3 HP 115V	170'	270'	420'	670'	1025'	1575'
1/2 HP 115V	160'	250'	390'	620'	960'	1460'
1/2 HP 230V	650'	1020'	1610'	2510'	3880'	5880'
3/4 HP 230V	480'	760'	1200'	1870'	2890'	4370'
1 HP 230V	400'	630'	990'	1540'	2380'	3610'
1-1/2 HP 230V	310'	480'	770'	1200'	1870'	2850'
2HP 230 V	250'	390'	620'	970'	1530'	2360'
3 HP 230 V	190'	300'	470'	750'	1190'	1850'

Refer to the chart left to determine the proper cable size and length for your particular pump. The maximum lengths listed are from the pump motor to the circuit breaker, not to the plug in. Improper wire size can cause unsafe operating conditions and damage the pump. **DO NOT use an extension cord to supply power to the motor** as this will put strain on and shorten the life of the pump motor.

Fig. 7

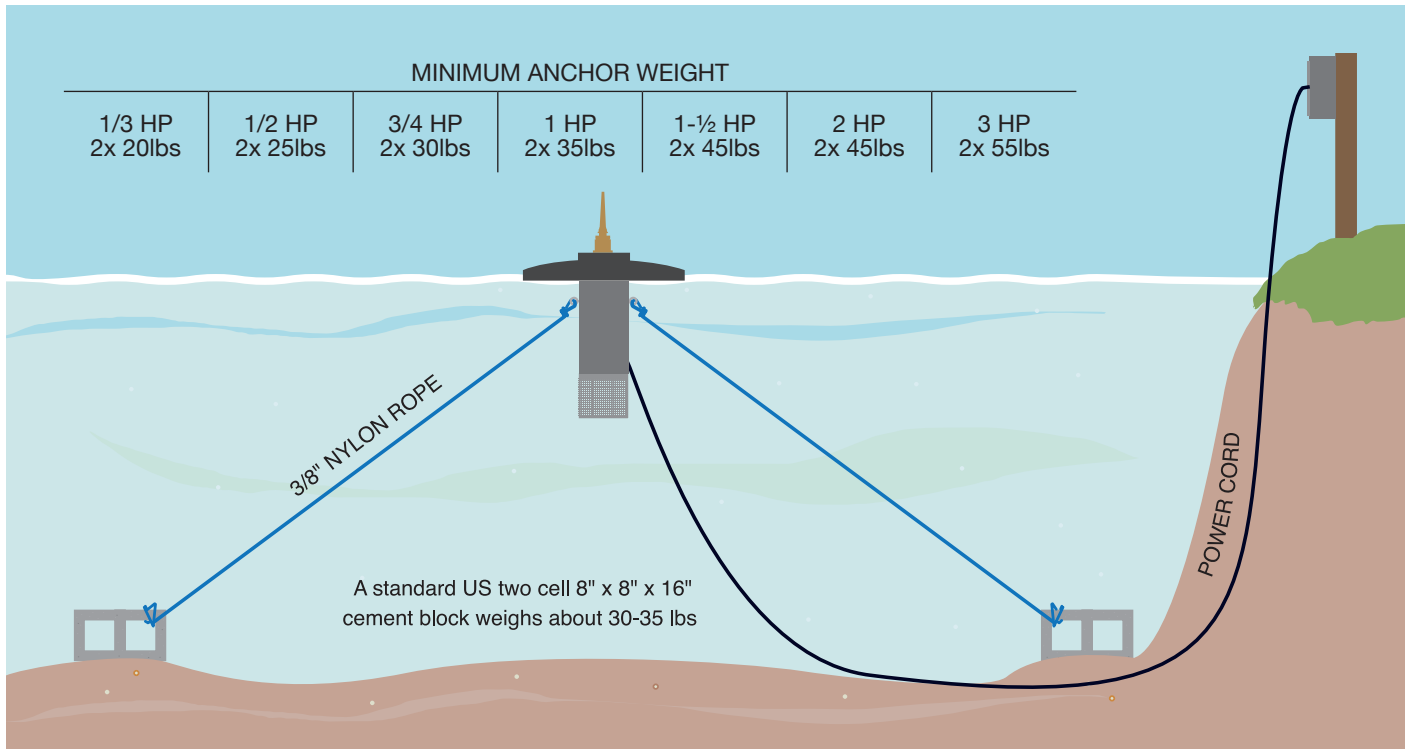

The Scott Aerator Awesome Warranty

All standard Scott Aerator products are unconditionally warranted for five years against motor defects in materials or workmanship, under normal operating conditions. All other product components are warranted for one year from date of purchase. Scott Aerator will repair or replace failed parts under warranty when the defective unit is returned to the factory, shipping prepaid, and factory inspection establishes that the part was defective. The unit must be returned to the factory prior to shipment of replacement parts. All parts replaced under this warranty will be returned with shipping prepaid. Scott Aerator will not be liable for consequential damage nor for any costs associated with removal or attempts to repair components in the field.



13245 Barry Street, Holland, MI 49424
scottaerator.com
information@scottaerator.com
800-WATER-45 (800-928-3745)
(616) 392-8882

